

# Cluster quantum-chemical MINDO/3 study of the nature of hydroxyl groups on a calcium oxide surface

N.U. Zhanpeisov<sup>a,b,\*</sup>, H. Nakatsuji<sup>a</sup>, M. Hada<sup>a</sup>

<sup>a</sup> Department of Synthetic Chemistry and Biological Chemistry, Faculty of Engineering, Kyoto University, Sakyo-ku 606-01, Kyoto, Japan

<sup>b</sup> Boreskov Institute of Catalysis, Prosp. Akad. Lavrentieva 5, 630090 Novosibirsk, Russia

Received 27 October 1995; accepted 29 February 1996

## Abstract

A modified MINDO/3 method was applied to study water molecule interaction with a pure calcium oxide using a supermolecular approach. The calcium oxide was modelled by a  $\text{Ca}_{32}\text{O}_{32}$  four-layer molecular cluster containing all sets of the most chemically active low-coordinated calcium and oxygen ions ( $\text{Ca}_{\text{LC}}^{2+}$  and  $\text{O}_{\text{LC}}^{2-}$ ). It is shown that the dissociative adsorption of water molecule on a pair of acid–base centers of CaO is energetically more favorable than the molecular forms of adsorption on an acidic sites. O–H stretching frequencies of six kinds of hydroxyl groups on a CaO calculated by a harmonic oscillator approach can be ascribed to the corresponding local structures.

*Keywords:* Calcium oxide; Water; Hydroxyl group stretching frequencies; MINDO/3 study

## 1. Introduction

Surface hydroxyl groups play an important role in the catalytic activity of many metal oxide surfaces, in particular on CaO and MgO [1–3]. From a theoretical point of view it is interesting to study the molecular mechanism of restoring of OH-cover on the oxide surface since they behave as active sites for many catalytic reactions. Experimentally the information on the nature of these OH-groups is usually obtained by means of conventional IR spectroscopy [3–5]. Recently we have shown [6] that six kinds of hydroxyl groups on a MgO surface,

which are experimentally observed by high temperature IR spectroscopic techniques using the deuterium exchange reaction of surface OD-groups with  $\text{H}_2$  on a MgO [7], can be very well described within the framework of the MINDO/3 method. To our knowledge no detailed theoretical studies have been performed both for the interaction of water molecule and for direct calculations of the band frequencies of surface OH-groups on a calcium oxide. In this connection it is interesting to find out how the band frequencies for surface OH-groups on CaO can be described within the framework of the MINDO/3 method. Such a direct calculations of the band frequencies for surface OH-groups will prove useful in interpreting the experimental data.

\* Corresponding author. Fax: +81-75-7535910.

## 2. Method of calculation and cluster model

The cluster quantum-chemical calculations were performed within the framework of the MINDO/3 method [8], whose parameterization has also been extended to consider calcium-containing compounds [9]. Calcium oxide which has rock-salt structure is modelled by stoichiometric molecular cluster of  $\text{Ca}_{32}\text{O}_{32}$  containing all sets of low-coordinated calcium and oxygen ions ( $\text{Ca}_{\text{LC}}^{2+}$  and  $\text{O}_{\text{LC}}^{2-}$ ) in various structural defects, i.e. corners, edges, faces, etc. (Fig. 1). Previously we have shown that the geometry relaxations can be correctly described within this optimized  $\text{Ca}_{32}\text{O}_{32}$  cluster, i.e. only a small difference between the optimized CaO bond length at the clean (001) surface of calcium oxide and the bulk value of 0.245 nm was observed, while three-coordinated corner calcium ions show much more geometry relaxation compared to the bulk [9]. In the following for all adsorption complexes presented here the internal coordinates of the adsorbate molecule were fully optimized, whereas only the active site(s) coordinates of the calcium oxide cluster were allowed to relax. Calculations of the O–H stretching frequencies  $\nu_{\text{OH}}$  of various surface OH-groups on CaO were carried out on the basis of a harmonic oscillator approach in the

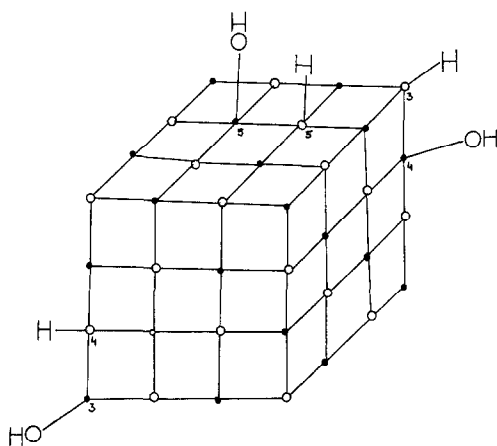

Fig. 1. Molecular cluster of  $\text{Ca}_{32}\text{O}_{32}$  with various types of surface hydroxyl groups. The numerals correspond to the degree of coordination of various centers:  $\circ$   $\text{O}_{\text{LC}}^{2-}$ ;  $\bullet$   $\text{Ca}_{\text{LC}}^{2+}$ .

locality of the total energy minimum represented by a parabola at the optimized distance  $R_{\text{OH}}$  and at  $R_{\text{OH}} \pm 0.0005$  nm as in [6,10,11]. These hydroxyl groups can be formed via dissociative adsorption of water molecules on CaO and differ from each other in the degree of coordination of hydroxyl group by metal atoms in the first and by oxygen atoms in the second coordination spheres (Fig. 1).

The Madelung field, i.e. the effects of long range Coulomb terms which can be easily described by embedding the cluster in an array of point charges has not taken into account. In the applied supermolecular approach the inclusion of the Madelung potential should not result in any essential distortion of the results calculated, since the chemical interactions on oxide surfaces are so local in the nature (see, for example, [10–13]).

## 3. Results and discussions

From a theoretical point of view for interaction of a water molecule with a CaO there can be either molecular or dissociative adsorption channels. In the former case a water molecule interacts with a surface acid site via coordination mechanism (Fig. 2a) or via forming a hydrogen bond with a surface basic site (Fig. 2b), while in the latter case it dissociates on a pair of acid–base centers (Fig. 2c). Calculated adsorption energies ( $\Delta E$ ) for various adsorption forms are shown in Table 1. There is also the main geometric characteristics of these complexes.  $\Delta E$  is calculated as an energy difference between an adsorbed complex and a sum of an initial cluster and a water molecule. It is clear that an increase in the coordination number both of  $\text{Ca}_{\text{LC}}^{2+}$  acid and of  $\text{O}_{\text{LC}}^{2-}$  basic sites leads to a decrease in an energetic effects of both adsorption channels. However, the four- and five-coordinated acid sites (i.e.  $\text{Ca}_{4\text{C}}^{2+}$  and  $\text{Ca}_{5\text{C}}^{2+}$  sites) display relatively the same activity in contrast to those of MgO [14–16]. Perhaps this is due to an increased basicity of calcium oxide compared to

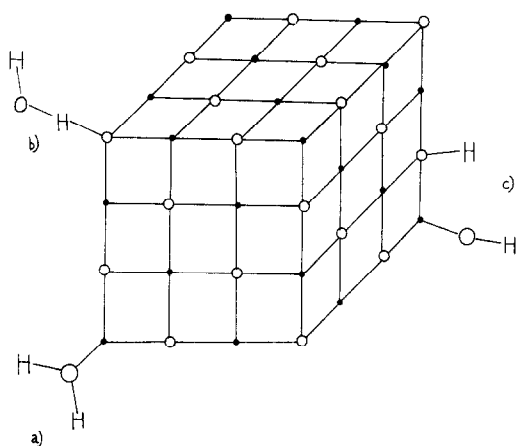

Fig. 2. Interaction of water molecule with a calcium oxide via (a) coordination to a surface acid site, (b) forming a hydrogen bond with a surface basic site and (c) dissociative adsorption on a pair of acid–base centers.  $\circ$   $O_{LC}^{2-}$ ;  $\bullet$   $Ca_{LC}^{2+}$ .

magnesium oxide [9,17]. For molecular adsorption of water the coordination mechanism is less favorable by energetics than that of H-bonding mechanism. In fact, in the latter case water molecule prefers to have an additional bond

formed between its O atom and the next-neighbor surface calcium atom. Calculated adsorption energies for these forms only slightly differs from those of the dissociative adsorption of water molecule on a respective pair of a next-neighbor acid–base centers. In the latter case the active acidic and basic sites were allowed to relax, while in the former case only a basic site is relaxed. Note the relaxation of an acid and a basic sites is much more pronounced under dissociative adsorption compared to molecular adsorption. This means that under dissociative adsorption an acid  $Ca_{LC}^{2+}$  and a basic  $O_{LC}^{2-}$  ions are substantially moved from their optimal positions within the non-interacting cluster to the direction of adsorbed fragments. If we fixed some degree of freedom for water molecule then H-bonding mechanism became less favorable by energetics (for example, cf. molecular water adsorption on three-coordinated  $O_{3C}^{2-}$  basic site, see Table 1).

Let us consider the nature of the surface hydroxyl groups on CaO. As is mentioned above

Table 1

Heats of adsorption ( $\Delta E$ , kcal/mol) of water molecule on pure calcium oxide and its geometry (bond lengths in nm, angles in degrees) as calculated by the MINDO/3 method

Type of active site	$\Delta E^a$	Geometry <sup>b</sup>
<b>Molecular adsorption</b>		
$Ca_{3C}^{2+}$	25.1	XC <sub>a</sub> , 0.0075; CaO, 0.2531; OH, 0.0950 (0.0950); HO <sub>s</sub> Ca, 126.6 (128.7)
$Ca_{4C}^{2+}$	20.8	XC <sub>a</sub> , 0.0062; CaO, 0.2557; OH, 0.0949 (0.0952); HO <sub>s</sub> Ca, 133.0 (121.5)
$Ca_{5C}^{2+}$	20.8	XC <sub>a</sub> , 0.0028; CaO, 0.2558; OH, 0.0953 (0.0952); HO <sub>s</sub> Ca, 126.7 (128.9)
$O_{3C}^{2-}$ <sup>c</sup>	9.7	YO, 0.0001; O <sub>s</sub> H, 0.1171; HO <sub>s</sub> Ca, 180.0; HO, 0.1181(0.0946); HOH, 108.9
$O_{3C}^{2-}$ <sup>d</sup>	54.6	YO, 0.0216; O <sub>s</sub> H, 0.0951; HO <sub>s</sub> Ca, 153.2; HO, 0.2465 (0.0937); HOH, 133.6; Ca <sub>s</sub> O, 0.2304
$O_{4C}^{2-}$ <sup>e</sup>	44.8	YO, 0.0301; O <sub>s</sub> H, 0.0966; HO, 0.1987 (0.0942); HO <sub>s</sub> Ca, 115.6; HOH, 138.6; Ca <sub>s</sub> O, 0.2436
$O_{5C}^{2-}$	25.9	YO, 0.0069; O <sub>s</sub> H, 0.1050; HO, 0.1412 (0.0944); HOH, 125.5; Ca <sub>s</sub> O, 0.2533
<b>Dissociative adsorption</b>		
$Ca_{3C}^{2+}-O_{4C}^{2-}$	59.4	XC <sub>a</sub> , 0.0303; Ca <sub>s</sub> O, 0.2217; OH, 0.0937; YO, 0.0097; Ca <sub>s</sub> OH, 169.7; O <sub>s</sub> H, 0.0958
$Ca_{4C}^{2+}-O_{3C}^{2-}$	59.8	XC <sub>a</sub> , 0.0072; Ca <sub>s</sub> O, 0.2263; OH, 0.0937; Ca <sub>s</sub> OH, 176.9; YO, 0.0196; O <sub>s</sub> H, 0.0949
$Ca_{4C}^{2+}-O_{4C}^{2-}$	36.7	XC <sub>a</sub> , 0.0282; Ca <sub>s</sub> O, 0.2296; OH, 0.0938; Ca <sub>s</sub> OH, 158.8; YO, 0.0198; O <sub>s</sub> H, 0.0959
$Ca_{4C}^{2+}-O_{5C}^{2-}$	26.7	XC <sub>a</sub> , 0.0037; Ca <sub>s</sub> O, 0.2247; OH, 0.0937; Ca <sub>s</sub> OH, 175.4; YO, 0.0502; O <sub>s</sub> H, 0.0965
$Ca_{5C}^{2+}-O_{4C}^{2-}$	34.9	XC <sub>a</sub> , 0.0332; Ca <sub>s</sub> O, 0.2256; OH, 0.0939; Ca <sub>s</sub> OH, 177.4; YO, 0.0394; O <sub>s</sub> H, 0.0957
$Ca_{5C}^{2+}-O_{5C}^{2-}$	24.9	XC <sub>a</sub> , 0.0229; Ca <sub>s</sub> O, 0.2287; OH, 0.0940; Ca <sub>s</sub> OH, 174.3; YO, 0.0335; O <sub>s</sub> H, 0.0966

<sup>a</sup> (+) sign means that the products are lower in energy than the reagents.

<sup>b</sup> X and Y correspond to an optimal position of acid and basic sites in the initial cluster, respectively. Subscript (s) relates to the surface atom.

<sup>c</sup> The  $HO_sCa$  angle, in which Ca atom is the next-neighbor bulk one, is fixed.

<sup>d</sup> The same as (c) but the  $HO_sCa$  angle is optimized.

<sup>e</sup> In the  $HO_sCa$  angle Ca atom relates to the next-neighbor three-coordinated corner calcium atom.

Table 2

O–H stretching frequencies ( $\nu_{\text{OH}}$ ,  $\text{cm}^{-1}$ ) of hydroxyl groups on CaO and their bond length ( $R$ , nm), bond order ( $P_{\text{OH}}$ ) and electron density on the OH bond ( $Q_{\text{OH}}$ ) as calculated by the MINDO/3 method<sup>a</sup>

Type of OH-group	$\nu_{\text{OH}}$	$\nu_{\text{OD}}$	$R_{\text{OH}}$	$P_{\text{OH}}$	$Q_{\text{OH}}$
Ca <sub>3C</sub> –O <sub>1C</sub> H	3667	2716	0.09392	0.961	–0.724
Ca <sub>4C</sub> –O <sub>1C</sub> H	3688	2732	0.09372	0.960	–0.732
Ca <sub>3C</sub> –O <sub>1C</sub> H	3700	2741	0.09367	0.952	–0.710
O <sub>3C</sub> H	3628	2687	0.09493	0.916	–0.549
O <sub>4C</sub> H	3549	2629	0.09567	0.911	–0.546
O <sub>5C</sub> H	3478	2576	0.09648	0.891	–0.525

<sup>a</sup> See text.

we can distinguish six types of hydroxyl groups on CaO which differ from each other in the degree of coordination by metal atoms in the first and by oxygen atoms in the second coordination spheres. These OH-groups are formed via dissociative chemisorption of water on CaO. Since at the Hartree–Fock level the calculated O–H stretching frequencies are overestimated [6,10,11] we used a scaling factor which is found from an optimal conformity of calculated and observed [18]  $\nu_{\text{OH}}$  for the terminal Ca<sub>3C</sub>–O<sub>1C</sub>H hydroxyl group. Table 2 shows the calculated  $\nu_{\text{OH}}$  using a scaling factor  $f = 0.93$ , there is also the calculated  $\nu_{\text{OD}}$  using well-known correlation  $\nu_{\text{OH}}/\nu_{\text{OD}} = 1.35$  [19] and O–H bond length ( $R_{\text{OH}}$ ), its bond order ( $P_{\text{OH}}$ ) and electron density on the O–H bond ( $Q_{\text{OH}}$ ). According to these calculations and in accordance with general ideas [3,20] the formation of a dative bond decreases the O–H stretching frequency, i.e. the hydroxyl group with a higher degree of coordination by metal atoms (O<sub>5C</sub>H) has the lowest band frequency. This is in line with the findings for hydroxyl groups on MgO [6] and due to the fact that increasing the coordination number of the OH-group by Ca atoms reduces the strength of the bond and leads to a lengthening of the O–H bond (see Table 2). The latter results in a decrease in the electron density on the O–H bond. O–H band frequencies for ‘on-top’ one-coordinated hydroxyl groups relatively weakly depends on the number of O atoms in the second coordination sphere. The highest  $\nu_{\text{OH}}$

corresponds to the one-coordinated OH-group bonded to three-coordinated Ca atom. However, in contrast to the similar OH-groups on MgO [6], there is only direct correlation between  $\nu_{\text{OH}}$  and  $R_{\text{OH}}$  or  $\nu_{\text{OH}}$  and  $P_{\text{OH}}$  and no correlation between  $\nu_{\text{OH}}$  and  $Q_{\text{OH}}$  for these ‘on-top’ hydroxyl groups. The reason of the reverse correlation between  $\nu_{\text{OH}}$  and  $P_{\text{OH}}$  could probably due to decrease in the OH bond ionic part and increase in the bond strength between OH-group and the surface acid site. Perhaps, these band frequencies can be also detected by high-temperature IR spectroscopic techniques using the deuterium exchange reaction of surface OD-groups with H<sub>2</sub> on CaO as in [7].

#### 4. Summary

The calcium oxide modelled by a Ca<sub>32</sub>O<sub>32</sub> four-layer molecular cluster containing all sets of the most chemically active low-coordinated calcium and oxygen ions (Ca<sub>LC</sub><sup>2+</sup> and O<sub>LC</sub><sup>2-</sup>) is found reliable to consideration of an adsorption processes on its surface and structural defect sites. It is shown that the dissociative adsorption of water molecule on a pair of acid–base centers of CaO is energetically more favorable than the molecular forms of adsorption on an acidic sites. OH-groups on a calcium atom are composed of three types, exhibiting different vibrations at 3700, 3688 and 3667  $\text{cm}^{-1}$ . In addition to these ‘on-top’ hydroxyl groups, there are three different kinds of multiply bridged OH-groups at 3628, 3549 and 3478  $\text{cm}^{-1}$ .

#### Acknowledgements

This work was supported in part by Japan Society for the Promotion of Science (JSPS) and by New Energy and Industrial Technology Development Organization (NEDO). N.U.Z. thanks JSPS for a grant for staying at Kyoto University under Fellowship Program for Research in Japan.

## References

- [1] T. Ito, T. Tashiro, M. Kawasaki, T. Watanabe, K. Toi and H. Kobayashi, *J. Phys. Chem.* 5 (1991) 4476.
- [2] T. Shido, K. Asakura and Y. Iwasawa, *J. Catal.* 122 (1990) 55.
- [3] A.A. Davydov, *IR-spectroscopy in the Chemistry of the Surface Compounds* (Nauka, Novosibirsk, 1984) (in Russian).
- [4] H. Knozinger, *The Chemistry of OH-groups* (Interscience Publishers, London, 1971).
- [5] E.A. Paukshtis and E.N. Yurchenko, *Adv. Russ. Chem.* 52 (1983) 426 (translated by Plenum).
- [6] N.U. Zhanpeisov, A.G. Pelmenshikov and G.M. Zhidomirov, *Mendeleev Commun.* (1992) 148.
- [7] T. Shido, K. Asakura and Y. Iwasawa, *J. Chem. Soc. Faraday Trans. 1*(85) (1989) 441.
- [8] R.C. Bingham, M.J.S. Dewar and D.H. Lo, *J. Am. Chem. Soc.* 97 (1975) 1275.
- [9] N.U. Zhanpeisov, V. Staemmler and M. Baerns, *J. Mol. Catal. A: Chem.* 101 (1995) 51.
- [10] N.U. Zhanpeisov, G.M. Zhidomirov and M. Baerns, *Zh. Strukt. Khim.* 35 (1994) 12 (translated by Plenum).
- [11] N.U. Zhanpeisov, E.A. Paukshtis, G.M. Zhidomirov and V.A. Zakharov, *Catal. Lett.* 29 (1994) 209.
- [12] N.U. Zhanpeisov, G.M. Zhidomirov and M. Baerns, *J. Mol. Catal. A: Chem.* 99 (1995) 35.
- [13] A.G. Pelmenshikov, G. Morosi, A. Gamba and S. Coluccia, *J. Phys. Chem.* 99 (1995) 15018.
- [14] N.U. Zhanpeisov and G.M. Zhidomirov, *Mendeleev Commun.* (1992) 111.
- [15] G.M. Zhidomirov and N.U. Zhanpeisov, *Catal. Today* 13 (1992) 517.
- [16] N.U. Zhanpeisov, A.G. Pelmenshikov and G.M. Zhidomirov, *Kinet. Catal.* 32 (1991) 970 (translated by Plenum).
- [17] G. Pacchioni, J.M. Ricart and F. Illas, *J. Am. Chem. Soc.* 116 (1994) 10152.
- [18] A.A. Tsyganenko, *Zh. Strukt. Khim.* 16 (1975) 572 (translated by Plenum).
- [19] B. Henderson and W.A. Sibley, *J. Chem. Phys.* 55 (1971) 1274.
- [20] A.A. Tsyganenko and V.N. Felimonov, *J. Mol. Struct.* 19 (1973) 579.